

PLAN VIEW

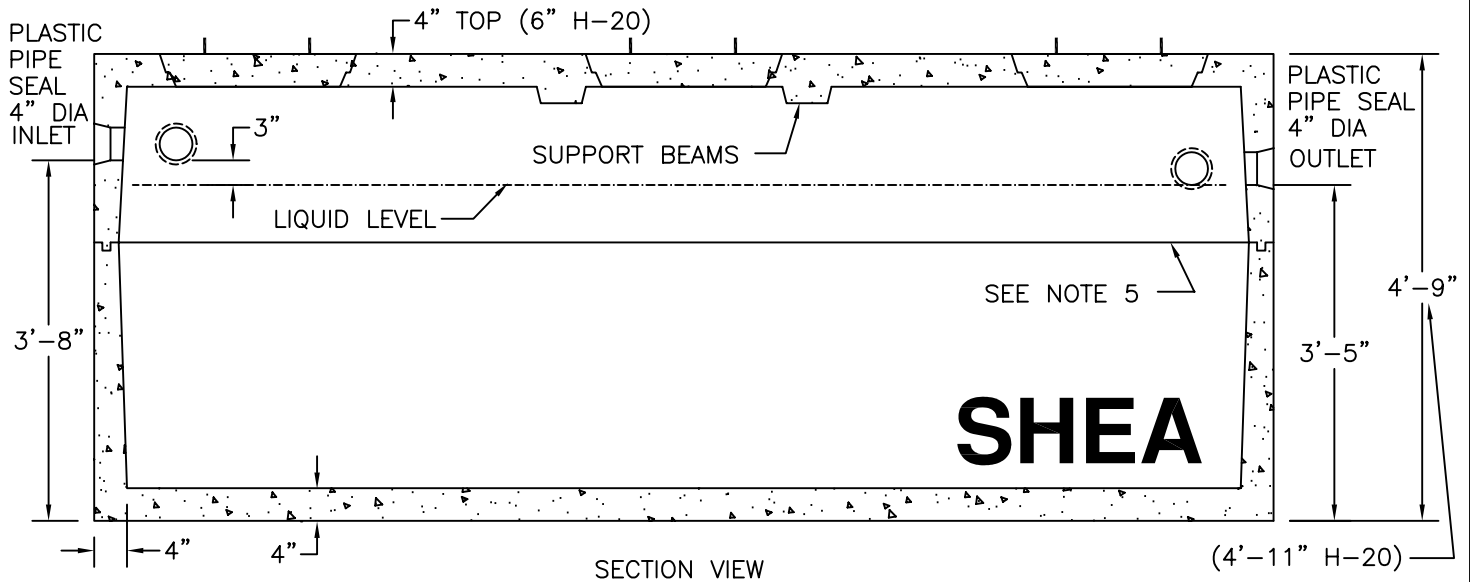

SECTION VIEW

		WEIGHT
ITEM NO.	TK-1500LB	STANDARD 13,025#
	TK-1500LBH	H-20 14,950#

NOTES:

1. CONCRETE: 4,000 PSI MINIMUM AFTER 28 DAYS.
2. DESIGN CONFORMS WITH 310 CMR 15.00, DEP TITLE 5 REGS, FOR REPLACEMENT SYSTEMS WHERE A LIQUID LEVEL OF FOUR FEET IS NOT FEASIBLE.
3. ALL REINFORCEMENT PER ASTM C1227-93.
4. TEES AND GAS BAFFLE SOLD SEPARATELY.
5. TONGUE & GROOVE JOINT SEALED WITH BUTYLE RESIN.
6. ALSO AVAILABLE IN H-20 LOADING.

E. F. SHEA
NEW ENGLAND
CONCRETE PRODUCTS, INC.

LEDGE TANK
1500 GALLON