

PLAN VIEW

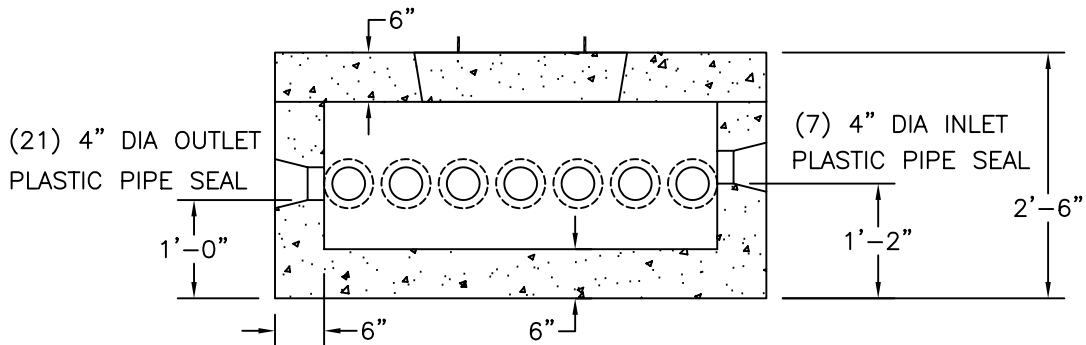

SECTION VIEW

			WEIGHT
ITEM NO.	B-21DBH	H-20 W/COVER	5,562#
	B-21DBC	COVER ONLY	1,850#

NOTES:

1. CONCRETE: 4,000 PSI MINIMUM AFTER 28 DAYS.
2. DESIGN CONFORMS WITH 310 CMR 15.000, DEP TITLE 5 REGS, FOR DISTRIBUTION BOXES.
3. DESIGNED FOR H-20 LOADING.

**E. F. SHEA**  
**NEW ENGLAND**  
**CONCRETE PRODUCTS, INC.**

DISTRIBUTION BOX  
 21 OUTLET  
 H-20