

TOP VIEW

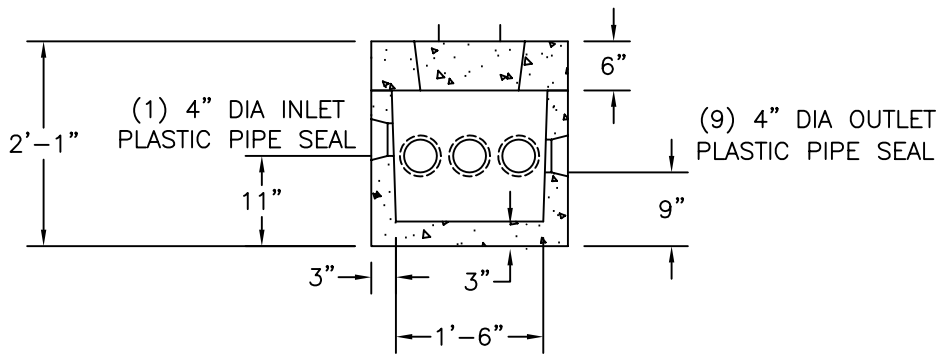

SIDE SECTION VIEW

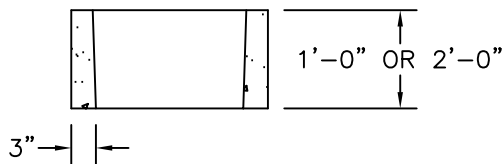

RISER SECTION

ITEM NO.	DESCRIPTION	WEIGHT
B-9DBH	W/COVER	687#
B-9DBHC	COVER ONLY	296#
B-9DBR12	RISER SECTION 12"	221#
B-9DBR24	RISER SECTION 24"	442#

NOTES:

1. CONCRETE: 4,000 PSI MINIMUM AFTER 28 DAYS.
2. DESIGN CONFORMS WITH 310 CMR 15.000, DEP TITLE 5 REGS, FOR DISTRIBUTION BOXES.
3. DESIGNED FOR H-20 LOADING.
4. OPTIONAL 18" ROUND OR SQUARE CAST IRON COVER AVAILABLE IN PLACE OF CONCRETE COVER.

E. F. SHEA
NEW ENGLAND
CONCRETE PRODUCTS, INC.

DISTRIBUTION BOX
 9 OUTLET